

Once the demand for distribution network availability and personal safety is in line with the effort required, an optimal solution has been found.



Option: Modbus



Universal-Indicator IKI-23_CAPDIS_top

- personal Safety
- complete directional fault detecting
- load flow measuring
- shield current measuring, step-voltage observation
- without external auxiliary-voltage

Ladies and Gentlemen,

comprehensive directional short-circuit and earth-fault detection combined with maximum personal safety is our claim and our contribution to increasing distribution network availability. While the IKI-50 feeder control unit meets the high requirements of remote-controlled Ring Main Units RMUs from fault detection to remote control, the IKI-23_CAPDIS_top closes the gap in nonremote-controlled distribution network systems in which often no auxiliary power is available. The IKI-23_CAPDIS_top is a complete solution that visualizes all relevant load flow and fault information and, if necessary, transmits it remotely. Compact secondary technology is the prerequisite for integration into existing primary technology and for digitizing the distribution networks. With the IKI-23, RMUS can also be completely monitored without external auxiliary power.

Clearly directional

In addition to a quick overview, a failure indication with detailed information is indispensable for clear and selective failure detection. The direction LEDs of IKI-23 offer rapid fault localisation and the detailed information offers the exact fault explanation.

Earth faults in compensated and isolated networks can only be detected selectively with reference to direction. IKI-23 is self-explanatory and its direction display is unique.

Double earth faults in closed loop rings often lead to confusing displays. Here, the IKI-23 pinpoints selectively up to the fault location.



In multiple cable systems, the damaged cable is identified by selective fault detection, so that operation can be continued at least with the undamaged cable.

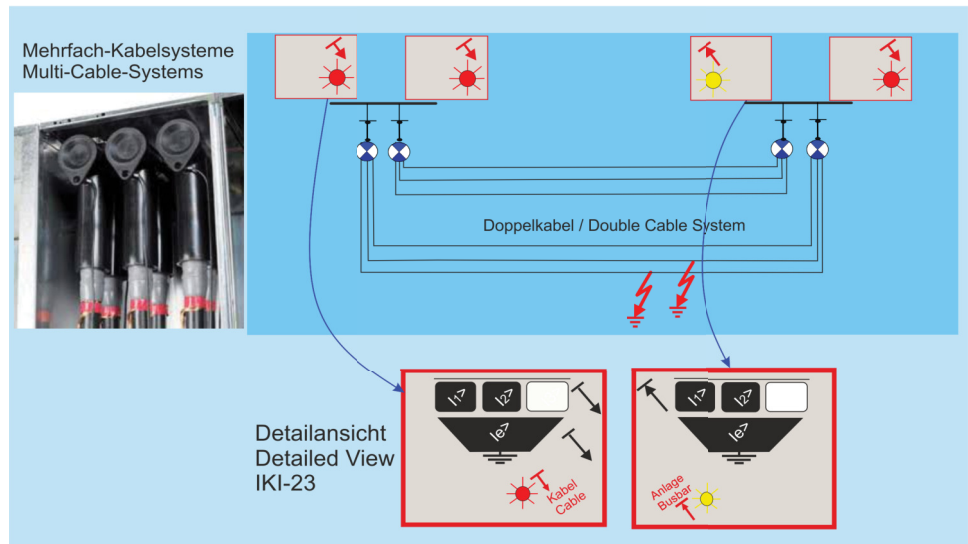
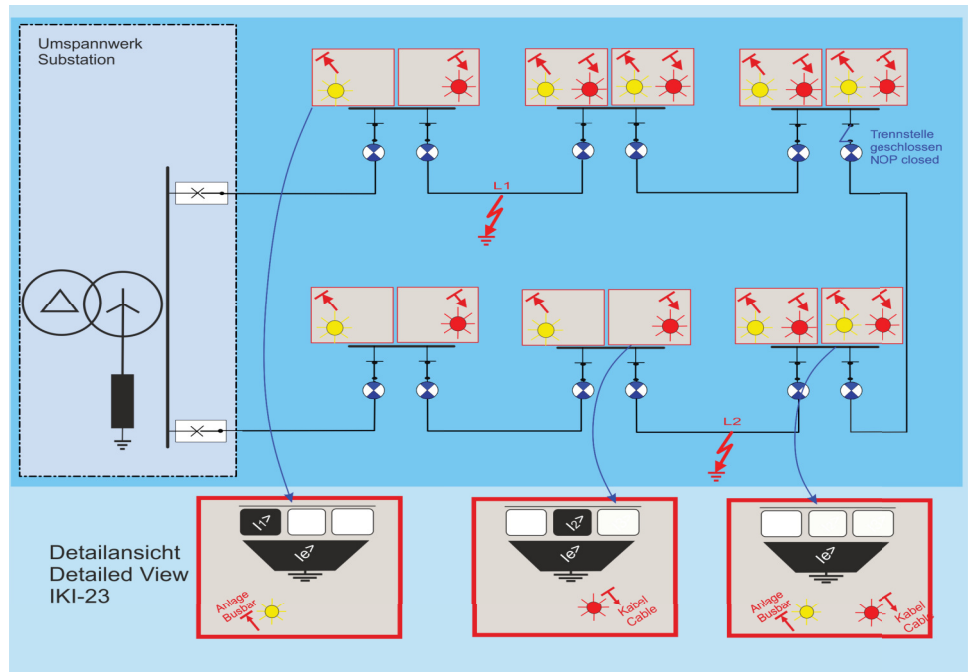

Compactness combined with universal functionality

The IKI-23 can be used both as an un-directed fault indicator and together with CAPDIS or with CAPDIS_top as a directional fault indicator.

The display of the IKI-23 satisfies the requirement of rapid fault location by means of two direction LEDs, but also provides detailed information about the affected phases for selective fault detection.

Correct installation is a prerequisite for correct direction indication. This is also indicated on the display by the rotating field for current and voltage.

Behind the protective cover of the IKI-23 there is an LRM interface according to IEC 61243-5, which can be connected to the capacitive tap of the switchgear and which is supplemented by plugging on a CAPDIS_top to form a fully integrated voltage detecting system VDS.

If the device is to be operated without detailed parameterization, the settings via the DIP switches are sufficient for the basic functions.

If additional fault algorithms (transient earth fault) and failure prediction are required, they are parameterised via the USB interface and the Kries-Config PC software. The Kries-Config software can also be used to read out the event memory or to update the firmware. The PC software can be downloaded free of charge from www.kries.com.

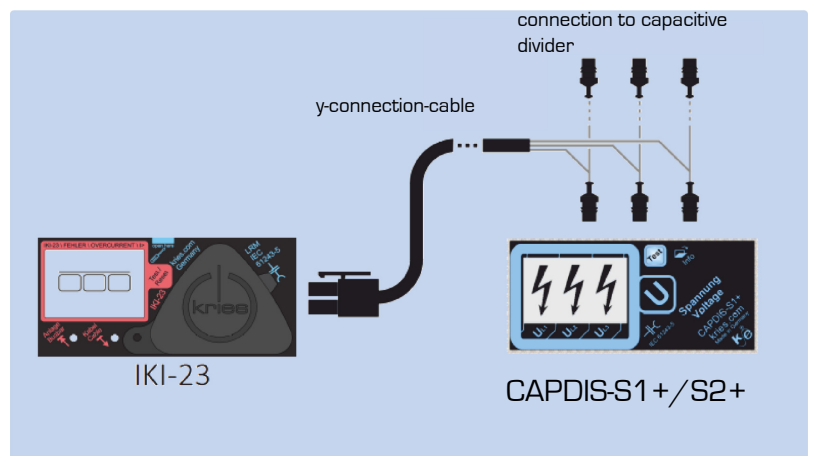
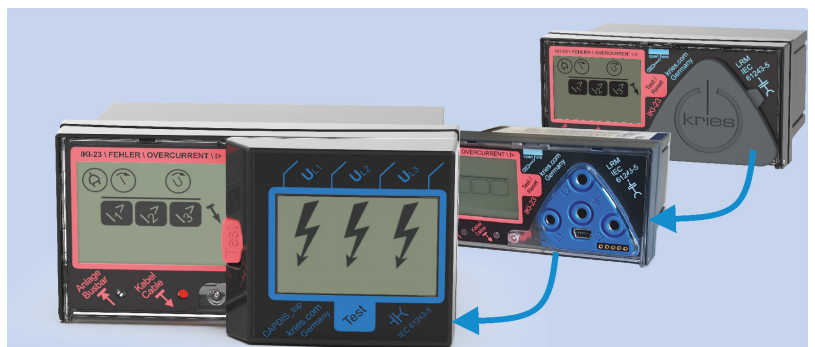
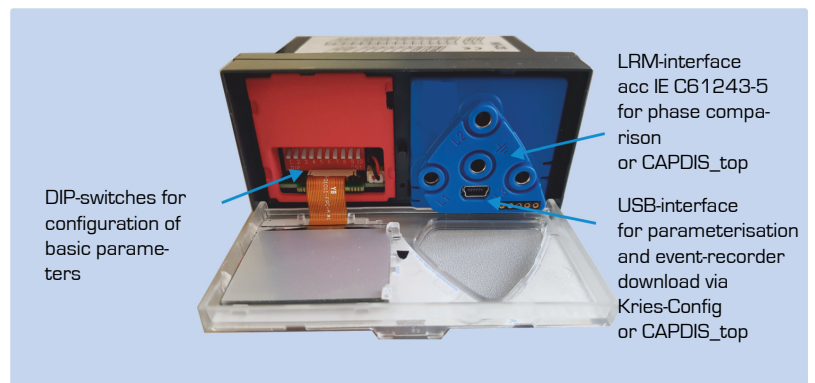
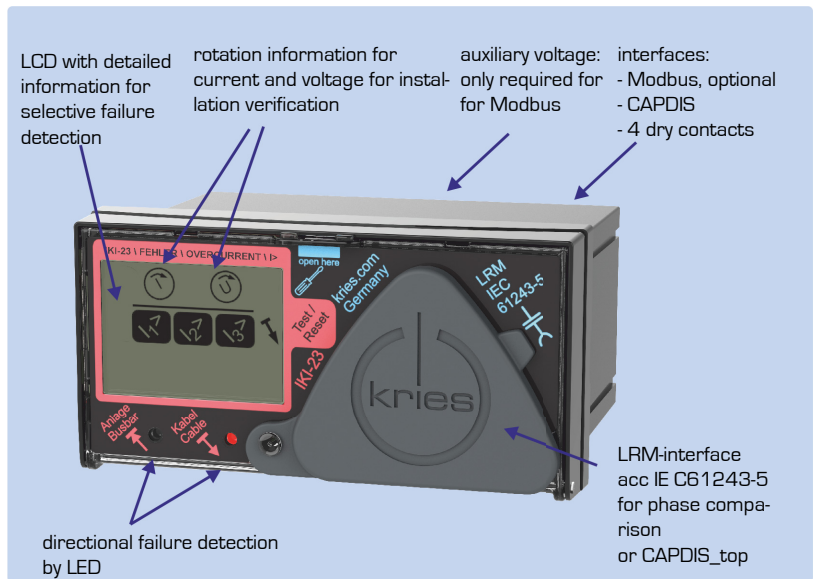

New functions offer increased personal safety and failure prediction

10-15% of all static earth faults start with intermittent earth faults. An increased density of the intermittent fault events results in a thermal overload of the equipment and thus an increased fire hazard.

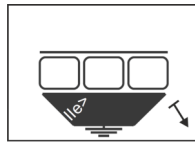

Intermittent Earth-fault indication with direction indication



If these insulation losses are detected at an early stage, problem areas in the distribution network can be detected before failures occur. The IKI-23 detects the intermittent faults and reports them depending on the set event density and amplitude threshold.

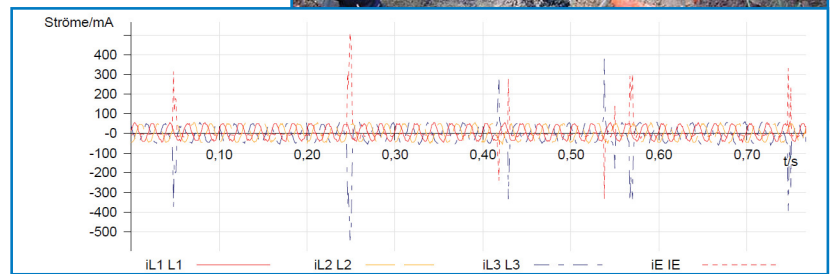

The IKI-23 offers a fourth current input which can be used to measure the shield current. By measuring the shield currents, the capacitive residual current can be monitored and cable or shield current overloads can be detected at an early stage.

Earthing systems are often not designed according to regulations or are not sufficiently low impedance due to aging and design defects. During a cable fault, the discharge of the residual current through the shield is no longer guaranteed. In these cases the personal protection depends on the earthing of the system. Step voltage monitoring enables the detection of insufficient system grounding and is a prerequisite for comprehensive personal safety. The step voltage is monitored by means of an earth spike and displayed on site when the danger threshold is exceeded, stored in the event memory and remotely signalled if necessary. In the event of earth faults, dangers for passers-by and operating personnel can thus be detected at an early stage.

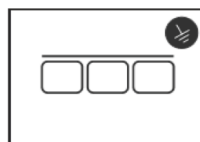

Indication of insufficient grounding or dangerous step voltage in the display. An external LED blinker unit can also be connected to the IKI-23, which is mounted on the outside of the kiosk-station, for example, and indicates the danger.



IKI-23_CAPDIS_top: The compact Universal-Indicator

In switchgear, the space for secondary technology is limited. Compact secondary technology reduces the effort involved in designing switchgear and simplifies operation and, of course, retrofitting.

All relevant electrical parameters can be determined from the measured variables current and voltage. CAPDIS capacitive voltage detection systems have established themselves for voltage detection. These are also suitable for transmitting the voltage signal for measurement.

The universal indicator IKI-23_CAPDIS_top combines all relevant functions for fault detection and load flow measurement in one device.

In gas-insulated switchgear, the current transformers can already be pre-assembled on the bushings. This simplifies the final installation of the cables and carries fewer risks due to installation errors (incorrect CT alignment or incorrectly returned shields).

In these systems, the voltage is taken directly from the capacitive decoupling of the bushing.

In air-insulated switch gears, terminations are often installed. In these systems, the combined U/I-sensor for current measurement and voltage detection can be retrofitted to the cable-termination without dismantling the cable.

The entire measuring system consists of three combined sensors and one IKI-23_CAPDIS_top and is installed in a very short time.

Combined U/I-sensors are also available for three-core cable terminations up to 13.8 kV, which together with the IKI-23_CAPDIS_top offer a compact and complete overall solution.



Optimized Distribution-Network Availability

Fault and insulation loss detection and load flow measurement for distribution networks with increased availability requirements

KI-23-CAPDIS_top does without external auxiliary power and balanced core CT and still offers the complete functionality:

- Directional short-circuit detection
- Directional earth short-circuit detection
- Directional earth fault detection with transient method
- Earth fault detection with pulse detection, the locating method with almost 100 % hits in the compensated network

Useful additional functions

- Step voltage monitoring for the grounding test
- Shield current monitoring
- Failure Prediction via intermittent earth fault detection
- Event memory for 20 events
- Optional Modbus interface for Current, cos phi, frequency, angle, error incl. direction
- Intermittent faults
- Events with time stamp



With the PC software Kries-Config, the IKI-23 can be parameterised individually and the event memories can be read out. The software is available for free download at www.kries.com at your disposal

