

IPC4020

Fault Detector and Remote Terminal Unit



IPC4020 is a fault detector for overcurrent and earth faults with integrated remote terminal unit functionality.

It has I/O for indications and orders and is therefore suitable for a typical secondary substation with up to four objects.

The standard IPC4020 detects faults on one feeder. It can be ordered with an expansion module that allows fault detection of two additional feeders.

The communication protocol is IEC 60870-5-101 or -104.

Since the algorithm for earth fault detection does not require any voltage measurement, IPC4020 provides very cost-efficient fault detection and grid automation with a high sensitivity for pass-through faults, also in networks where the earth fault currents are low.

IPC4020

Fault Detection

Overcurrent, I> and I>>

Settings overcurrent 0.0 – 10 000.0 A, 0 – 10 000 ms.

Earth Fault, I₀>

Protrol's patented *Fault Pass Through* earth fault detection for all indirectly earthed networks. Capable of detecting high impedance and arcing earth faults. Note that no voltage measurement is necessary for good selectivity at very low currents. The sensitivity is comparable with conventional wattmetrical directional earth fault protective relays.

Settings high impedance earth fault 0.1 A – 100.0 A, 0 – 10 000 ms.

An arcing fault is concluded after two earth fault starts within a settable time, range 0 – 25 000 ms.

A non-directional earth fault stage is integrated.

Transient Fault Recorder

The built-in transient fault recording function registers currents and events from the last detected faults. It is possible to connect to the service port to analyse signals and events in detail. The transient fault recordings can be downloaded using the web interface and be analysed using Protrol Tool. The registered data can also be converted to COMTRADE format.

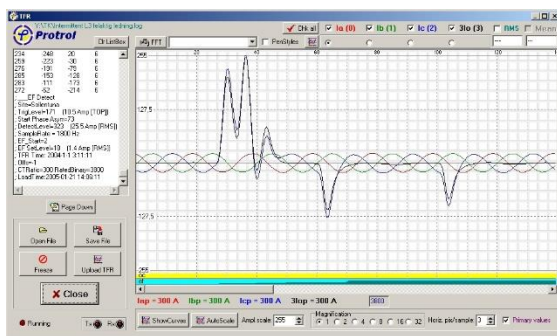

Remote Terminal Unit

Binary objects: 16 inputs (Single Point / Double Point). Objects for Start and Trip I> / I>> / I₀>, phase break, non-directional I₀> (Single Point).

8 outputs (Single Cmd / Double Cmd). Various objects for custom functions and remote acknowledge (Single Cmd).

Analog objects (spontaneous reporting with settable dead band 0.5 – 100%):

- Phase currents, rms
- Maximum current
- Average current 15 min
- Max fault current, I>/I>>
- Residual current, 3I₀
- Faulty phase(s), I>/I>> or I₀>
- Temperature

Expansion

IPC4020 can be specified for fault detection of one line and in a larger version for three lines. This means that an expanded IPC4020 can handle a 3+1 secondary substation; fault detection of three lines/cables and indications/orders for four objects.

IPC4020exp is ordered as a separate article. The extra current inputs for the two extra lines are located to the left of the standard terminals of IPC4020. Also refer to the sections 'Ordering Information' and 'Overview Diagram'.



Other Functions

HMI – User Interface

Detected overcurrent or earth fault is indicated by LEDs and can be acknowledged by a push button, remote control and/or after a pre-defined time up to 48 h.

Separate LEDs indicate status for power supply, internal supervision and activity of the communication ports.

Configuration is done using the built-in web interface.

Web Interface

The IPC4020 has a web interface that facilitates remote access using TCP/IP. In this interface it is possible to access status information and to configure the device. It is also possible to upgrade firmware and download transient fault recordings.

Master for Slave RTUs

IPC4020 can act master (IEC -101) for slave RTUs in a local bus. Independent on how many slave RTU nodes the IPC4020 polls, the remote master will only address one device. The interface is two-wire RS485 (terminal X13).

The slave RTU function is specified as an option at order, refer to section 'Ordering Information'.

Customer Adaption

The IPC4020 software can optionally be adapted to special customer needs (PLC function).

Technical Data

Allmänt

Dimensions ¹ :	195(290) x 105(115) x 75(80) mm. (l x w x h)
Assembly:	DIN bracket
Ambient temp:	-20 – +60 °C
Supply voltage:	24 – 48 VDC
Supply current:	appr 100 mA ² at 24 VDC
Standards:	EN 61000-6-2 – Immunity EN 61000-6-4 – Emission Class B EN 61000-6-5 – For installation in medium voltage substations

¹ Length 290 mm is for IPC4020exp. The dimensions 115 mm and 80 mm includes the female contacts.

² 100 mA is the supply current for IPC4020.

Tests according to: EN 61000-4-2
EN 61000-4-3
EN 61000-4-4
EN 61000-4-6

EU directives: ROHS, EMC

Service Port:

USB: Type B

Ethernet: RJ45 10/100Base – TX Full Dupl.

Inputs and Outputs:

Binary inputs: 16 BI, 24 – 110 VDC

Binary outputs: Two groups with 2 relays, 8 A breaking current at 250 VAC / 30 VDC (contacts X8 and X10).
Two groups with 2 relays³, 5 A breaking current at 250 VAC / 30 VDC (contacts X7 and X9).

Analogue inputs: 3 AI, 1 A (+ 6 AI, 1 A)⁴

All binary in- and outputs are equipped with LED indications

³ These can in one group be replaced with a latching relay when needed.

⁴ In total, 9 analogue inputs with expansion module connected.

Time Synchronisation:

Standard: IEC60870-5-101/104, or (S)NTP

System Port, slave:

RS485(-422)/RS232: Plugin contact/DSUB9
Both 2- and 4-wire communication are supported using RS485. Bus termination can be done by connecting X11:4 and X11:5, also see section 'Overview Diagram'.

Ethernet: RJ45 10/100Base – TX Full Dupl.

Communication Protocol, slave:

Standard: IEC60870-5-101/104

System Port, master:

RS485: Plugin contact.
2-wire communication. Bus termination can be done by connecting X13:2 and X13:3, also see section 'Overview Diagram'.

Ordering Information

Article Number

The article number is specified as 10114x(-W-XYZ).

Basic version IPC4020: 101140

Basic version IPC4020exp: 101143

Options

IPC4020 can be ordered with additional functionality which is specified by the following postfix to the article number of the basic version.

Option W = Version type 0-9

Option 0: – Basic version

Option X = Hardware options 0-9⁵

Option 0: – Basic version, no options

Option 1: – RS232 interface

Option 2: – Latching relay at output X7

Option Y = Software options 0-9⁵

Option 0: – Basic version, no options

Option 1: – Auto-reclosing function

Option 2: – IEC -101 master

Option Z = Other adjustments 0-9

Option 0: – Standard

Option 1-9: – Software version 1-9

⁵ Calculation of article number for options according to table:

Article Number	Option 3	Option 2	Option 1
0 - No options	-	-	-
1 - Option 1	-	-	X
2 - Option 2	-	X	-
3 - Option 1 & 2	-	X	X
4 - Option 3	X	-	-
5 - Option 1 & 3	X	-	X
6 - Option 2 & 3	X	X	-
7 - Option 1 & 2 & 3	X	X	X

Example article number

IPC4020 with IEC -101 master: 101140-0-020

IPC4020 with RS232 interface and latching relay at output X7: 101140-0-300

Overview Diagram

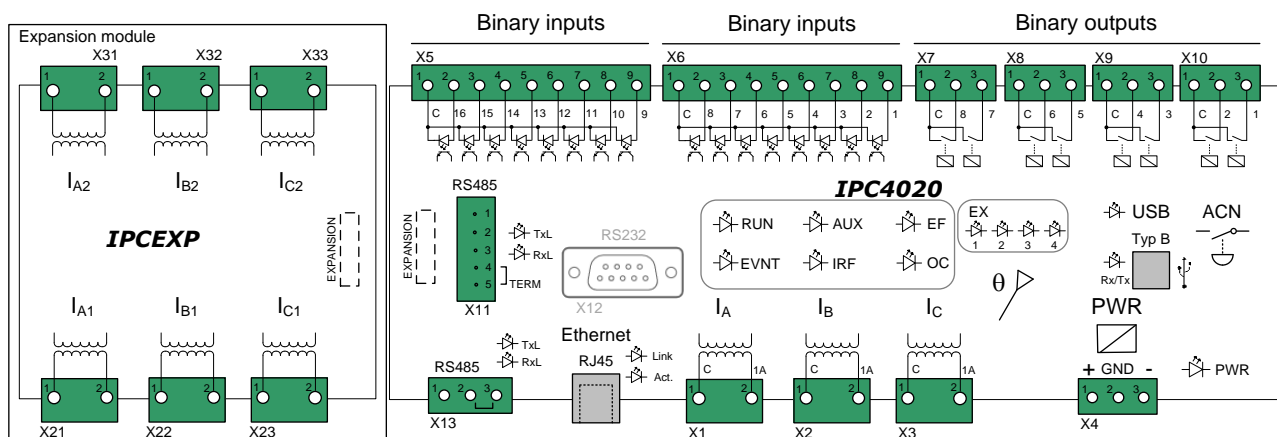

Typical Application

IPC4020exp can handle a 3+1 secondary substation; fault detection of three lines/cables, indications and control of four objects.

